



# Assembly Instructions for Chair No. DC206

## PARTS LIST

KEY	QTY	DESCRIPTION
1	5	GLIDE
2	1	BASE
3	1	SEAT POST
4	4	SEAT PLATE SCREW
5	1	SEAT PLATE
6	1	SEAT

### PREVENTIVE MAINTENANCE AND WARNING

- USE THIS PRODUCT ONLY FOR SEATING ONE PERSON AT A TIME
- DO NOT USE CHAIR AS STEP STOOL/ADDER.
- DO NOT USE CHAIR UNLESS ALL BOLTS, SCREWS AND KNOBS ARE TIGHT.
- AT LEAST EVERY SIX MONTHS, CHECK ALL BOLTS, SCREWS AND KNOBS TO BE SURE THEY ARE TIGHT
- IF ANY PARTS ARE MISSING, BROKEN, DAMAGED OR WORN, STOP USE OF THE PRODUCT UNTIL REPAIRS ARE MADE USING FACTORY AUTHORIZED PARTS.
- FAILURE TO FOLLOW THESE WARNINGS CAN RESULT TO SERIOUS INJURY.

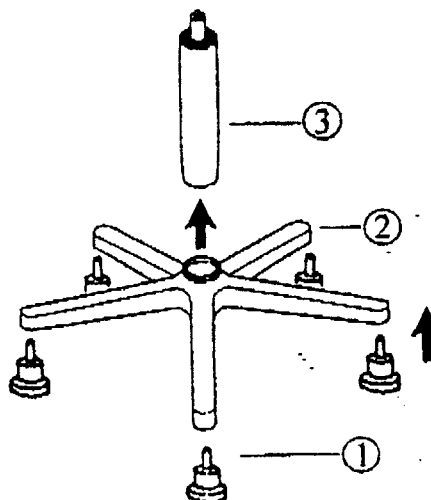

### STEP 1.

- Insert (1) glides into (2) base. Insert (3) seat post into (2) base.

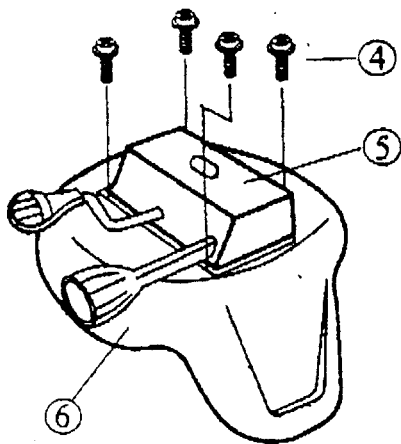

### STEP 2.

- Align (5) seat plate to pre-drilled holes of the back of (6) seat and securely tighten with (4) seat plate screw.

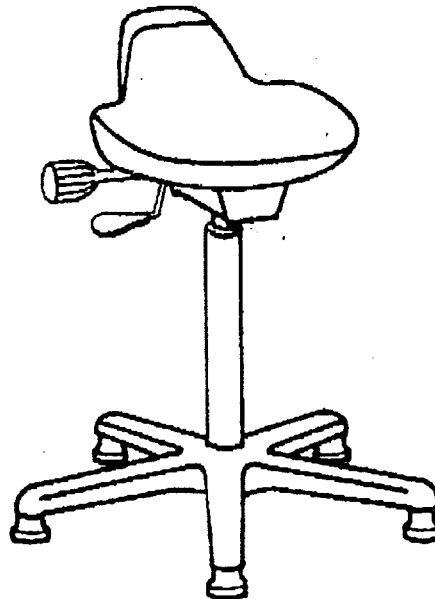

### STEP 3.

- Place upper assembled portion of chair into (3) seat post.

