



**BEST
ARTIST'S
PRODUCTS**

HOW TO ASSEMBLE THE CLASSIC SANTA FE I & II BEST EASELS

#880300(Classic Santa Fe I) & #880350(Classic Santa Fe II)

Best Artist's Materials - A Richeson Co. - Kimberly, WI 54136-0160 - Phone: 1-800-833-2378

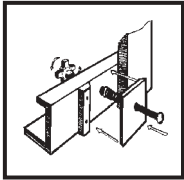

Height & tray adjustments unlock easily, yet lock into place & stay locked because of the **Wedge-lok System**.

The metal plate features wedge-cut edges that conform to the wedge-cut sections of the hardwood. When the knob is tightened, the inward tension pulls the metal plate snugly against the wood for a solid lock. In the event the bottom canvas holder will not tighten firmly, please contact a sales person at Jack Richeson & Co., Inc. 1-800-233-2404

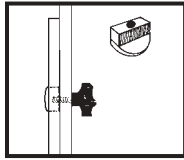

Slide Guides make angle and height adjustments on Best easels smooth. These circular graphite impregnated plastic inserts are used

wherever there is a slot in the wood of the easel. This part allows for smooth movement and protects the hardwood from the metal bolt.

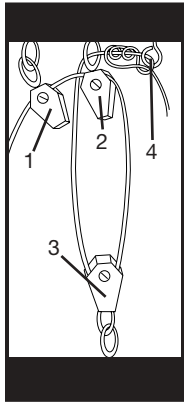

Pulley System

Insert rope through **Pulley 1**, then through **Pulley 2**. Pull rope down through **Pulley 3**, then back up through **Pulley 2**'s hook attachment. Thread rope through hook screw on right. Wrap back around rope itself several times then knot securely.

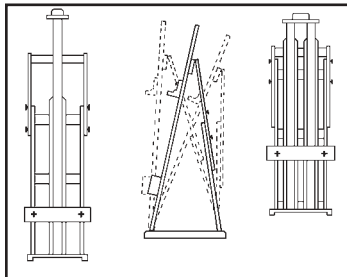

Achieve these angles with either the **Classic Santa Fe I** or the **Classic Santa Fe II** by using the **Slide Guide System** explained in diagram above.

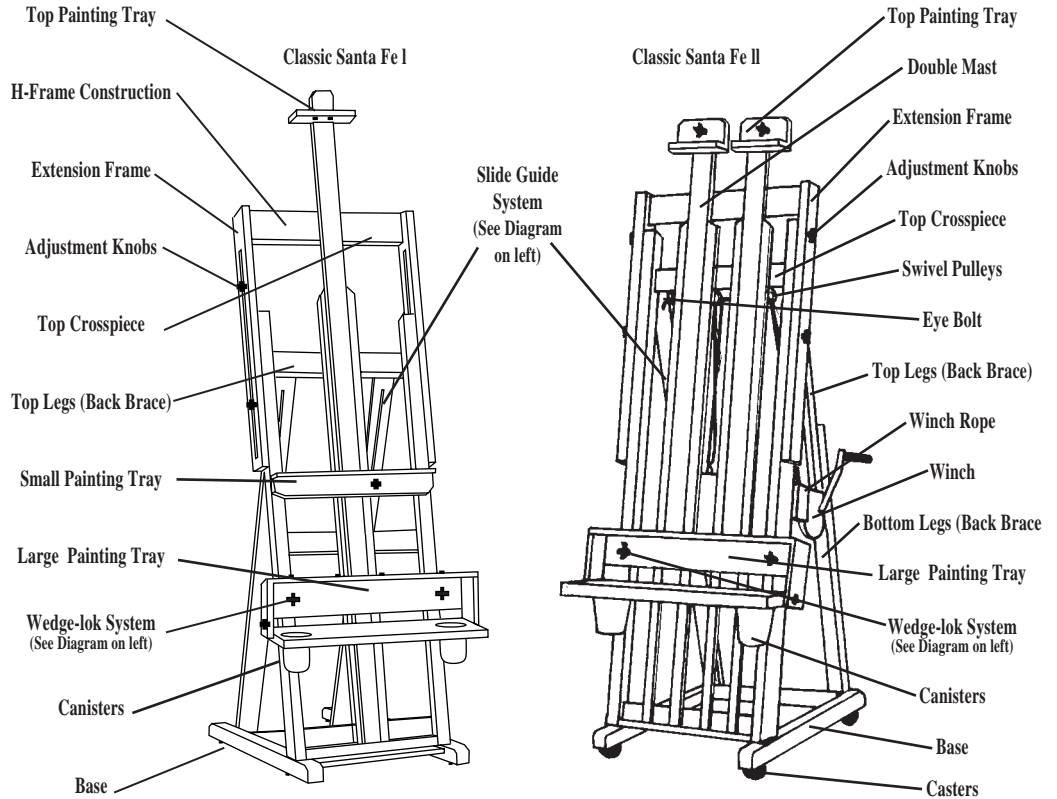

Easel Assembly - Classic Santa Fe I

- 1.) Set easel on base. Open up, tighten knobs and use the **Slide Guide System** to get easel to the desired angle.
- 2.) Slide the Mast out and turn it around. Position high to start.
- 3.) Large Paint Tray - loosen **Wedge-lok System**. Attach to easel by sliding down Mast then tighten black knobs. Proceed to tighten small black knobs on side for tray. Use the same procedure for Small Paint Tray. Complete by putting in utility tray and canisters.

Easel Assembly - Classic Santa Fe II

- 1.) Repeat steps 1 & 2 from above.
- 2.) Attach Pulley Box to easel. Start the 5 wood screws on pulley box, position over pre-drilled holes on base of easel and secure to easel by tightening screws.
- 3.) To put handle on, take large bolt off, put handle on and tighten bolt.
- 4.) Large paint tray - loosen **Wedge-lok System**. Attach to easel by sliding down mast then tighten black knobs. Proceed to tighten small black knobs on side for tray. Use the same procedure for Small paint tray. Complete by putting in utility tray and canisters.
- 5.) To install **Pulley System**, please see diagram at left.